

CHIKOUSA

CK- | STEEL SOLAR CARPORT | GAZEBO

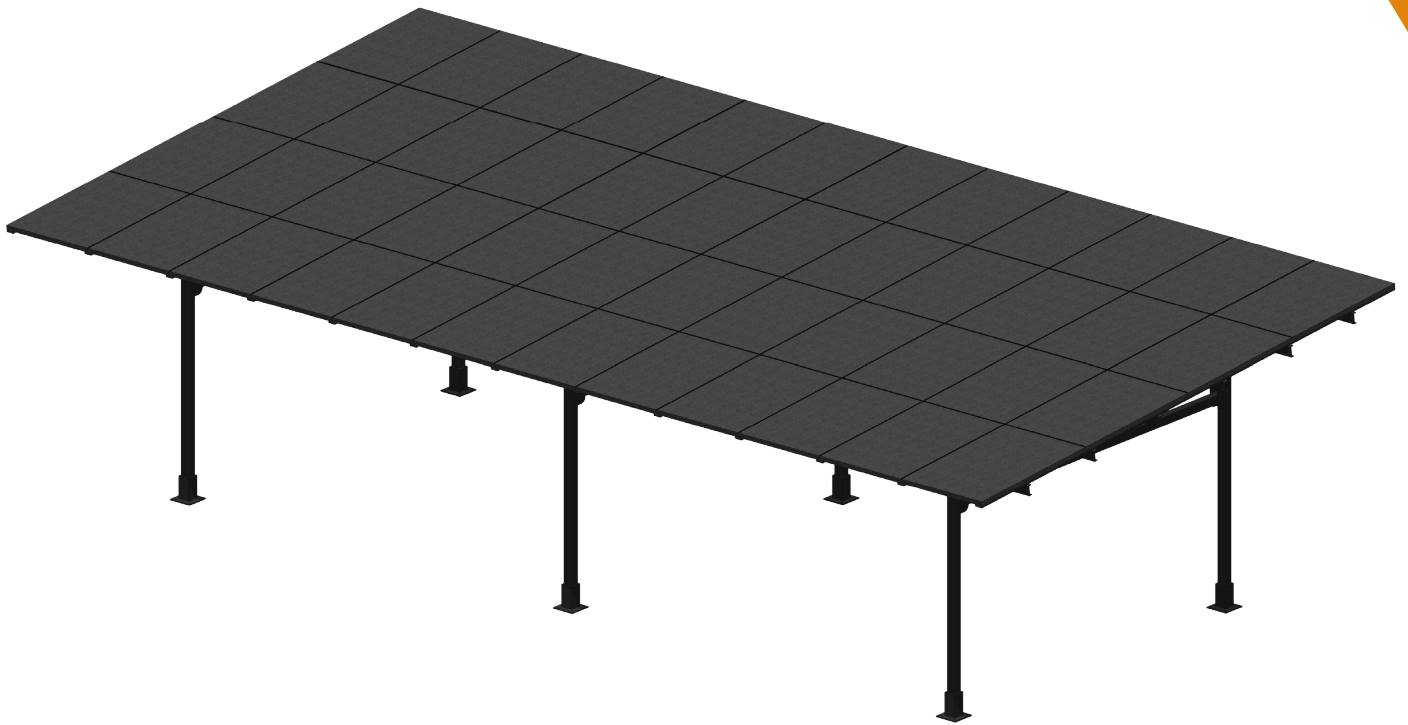

**4-CAR PREMIER
STEEL SOLAR CARPORT | GAZEBO
INSTALLATION MANUAL**

VERSION: 03.19.23 VO2 | ENG

Always use the most recent version of the installation manual before installing your Carport/Gazebo. The installation Manual is subject to change without notice. Please consult with CHIKOUSA to ensure you are utilizing the latest Install Manual.

BRIEF DESCRIPTION

The CK-Steel Carport/Gazebo is a robust solar carport that can accommodate a wide range of panel sizes, with a max (North/South or Up/Down) span of 270". This structure can be installed with a 2-3 person crew, without the need of any heavy duty tools. The Installation should always be completed by trained professional and/or qualified individuals, who have been adequately instructed and trained about the tasks involved with the installation, including the usage of protective devices, protective measures, relevant provisions, safety regulations and local operating site conditions and have proven competence in all areas of the installation.

Please read carefully this installation manual and all other applicable documents before starting your installation. Please contact CHIKO with any questions that you may have.

MAINTENANCE

1. When signs of rust appear, or when the paint is peeled or removed, you must take steps to remove the rust and paint the affected areas.
2. You must check the bolts once a year ensuring all connections are secure, and after any major storm or weather occurrence. Tighten all bolts according to torque specs.
3. If the columns of the structure are hit, you must replace the columns of the structure immediately.

WARNING

If any structural component of the system to include the column, beam, base plate, or rail are damaged they must be replaced immediately.

FOOTER WARNING

Anyone who plans to dig should call 811 or visit their state's 811 center's website a few business days before digging to request that the approximate location of buried utilities be marked with paint or flags so that you don't unintentionally dig into an underground utility line.

MEASUREMENT NOTE

All measurements have been converted from MM to Inches. The accuracy of measurement can vary slightly from mm to inches. All measurements are available in MM for detailed accuracy. The most critical measurement required is the Base Plate placement location. Please review the Construction Drawings for the Base Plate and Base Plate locations prior to installation.

REQUIRED INSTALLATION TOOLS

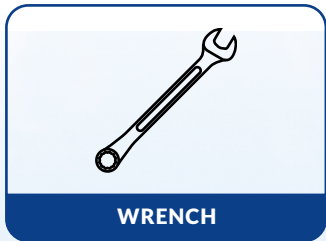
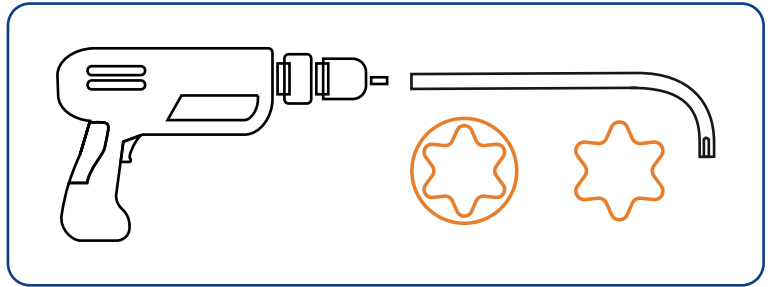
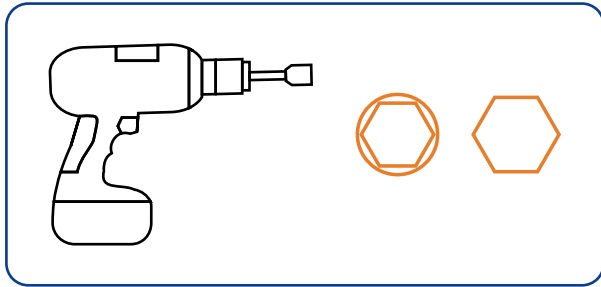

WRENCH



GLOVES



CHALK LINE

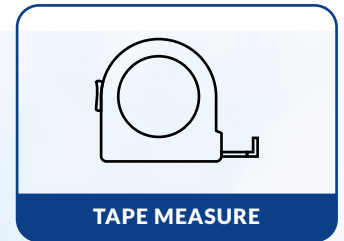

TAPE MEASURE



RUBBER MALLET



HARDHAT



SAFETY GLASSES

MAIN COMPONENTS



142 $\frac{1}{8}$ "

M RAIL



C-RAIL FIXED KIT

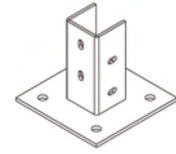

BASE PLATE



16 $\frac{1}{2}$ "

LOWER BEAM &
DIAGONAL BRACE ADAPTER

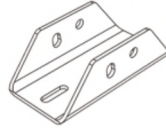

10 $\frac{3}{16}$ "

TOP COLUMN ADAPTER

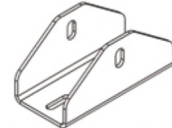

10 $\frac{3}{16}$ "

DIAGONAL BRACE ADAPTER

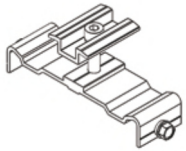

MID-CLAMP

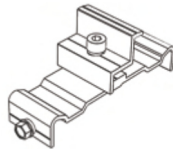

END-CLAMP



WATER CHANNEL



WATER-PROOF RUBBER

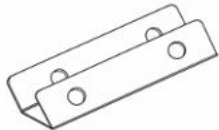

16 $\frac{1}{2}$ "

LOW BEAM/DIAGONAL BRACE ADAPTER

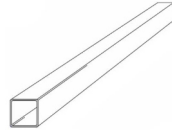

111"

FRONT COLUMN

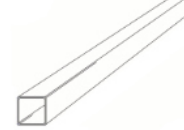

126 $\frac{1}{2}$ "

REAR COLUMN



224 $\frac{7}{16}$ "

L-ANGLE SUPPORT



228 $\frac{5}{16}$ "

SUPPORT BEAM

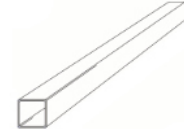

168 $\frac{1}{8}$ "

LOWER HORIZONTAL BEAM

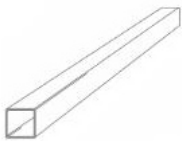

47 $\frac{1}{4}$ "

DIAGONAL BRACE

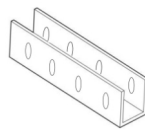

11 $\frac{13}{16}$ "

C-RAIL SPLICE



220 $\frac{1}{2}$ ", 215 $\frac{1}{16}$ ", 120 $\frac{3}{16}$ "

C-CHANNEL

NOTE

Customer needs to source materials for footings based on structural engineer specifications.

MAIN COMPONENTS

Overview

The following is a diagram that lists the main components of the CK- Carport System.

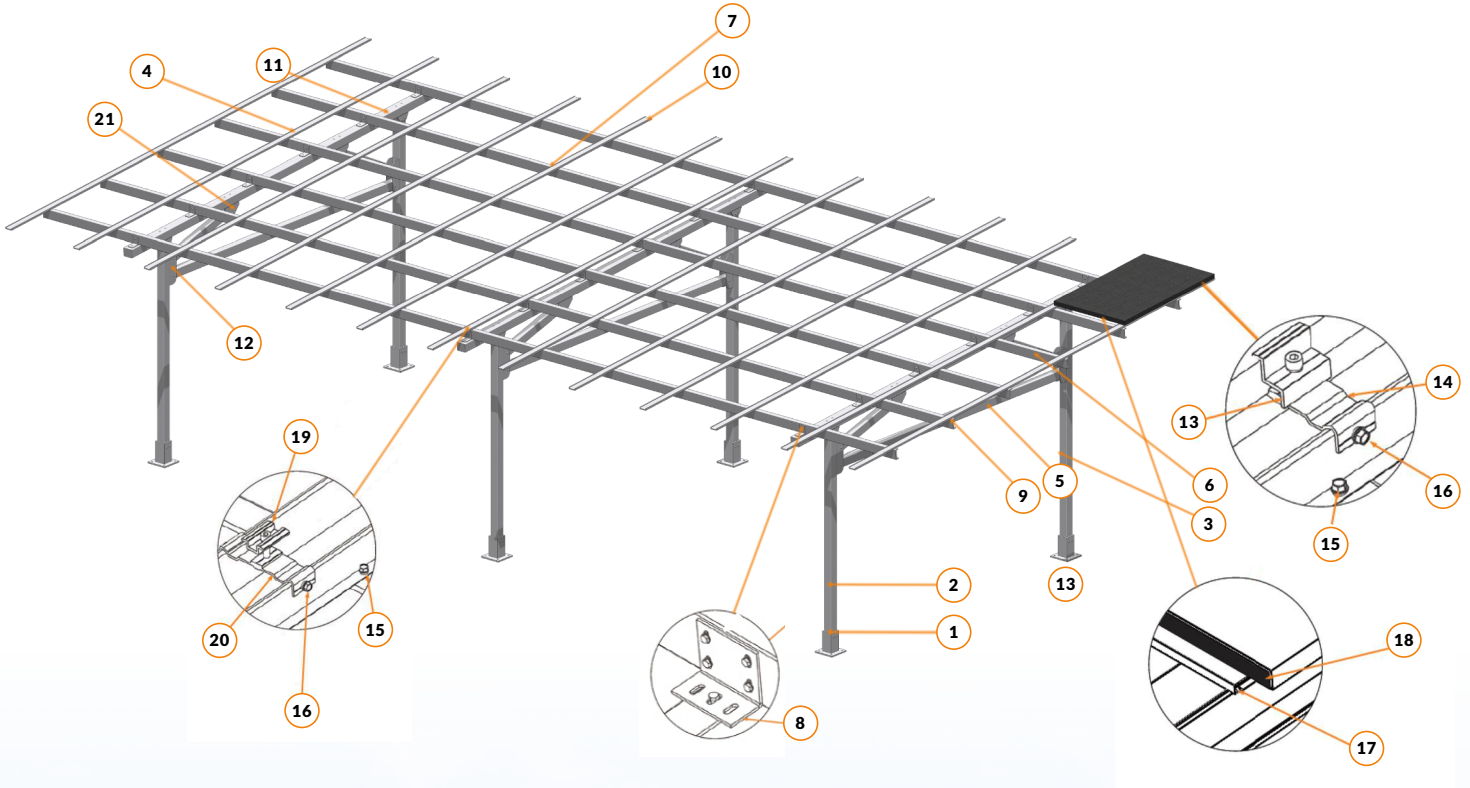

No	Description	QTY
1	Base Plate	6
2	Front Column 111"	3
3	Rear Column 126½"	3
4	Support Beam 228¾"	3
5	Lower Horizontal Beam 168½"	3
6	Diagonal Brace 47¼"	6
7	L-Angle Support 224¾"	4
8	C Rail Fix Kit	18
9	C-Channel 220½"	6
	C-Channel 215½"	
	C-Channel 120¾"	
10	M-Rail 142½"	20

No	Description	QTY
11	Top Column Adapter 10¾"	6
12	Low Beam & Diagonal Brace Adapter 16½"	6
13	End Clamp 30, 35, & 40MM	16
14	End Clamp Share Plate	16
15	M10*35 Bolt Kit	168
16	M16*180 Bolt Kit	156
17	Water Channel	36
18	Waterproof Rubber	
19	Mid Clamp	88
20	Mid Clamp Share Plate	88
21	Diagonal Brace Adapter 10¾"	6
22	C-Channel Splice	12



FRONT VIEW



SIDE VIEW

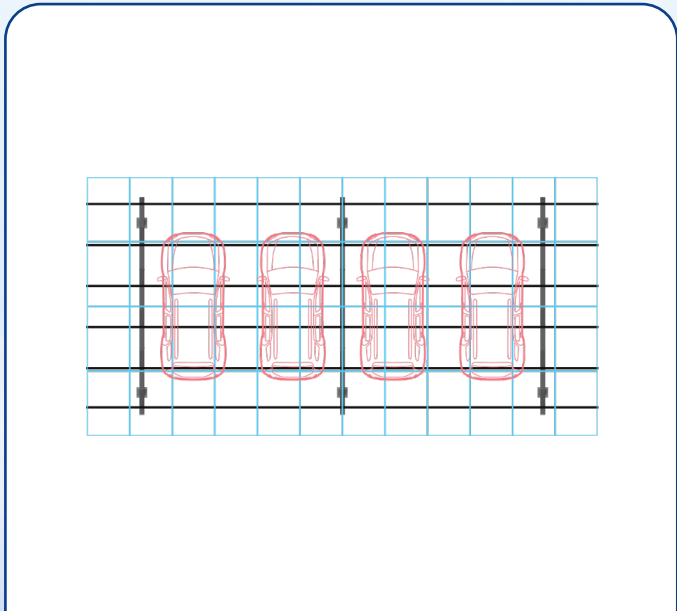

OVERHEAD VIEW



LARGE FORMAT MODULE VIEW

COMPONENTS LIST

CAT	Picture	Description Part	Details	QTY
1		Carport Support Structure	Front Columns	3
			Rear Columns	3
		CK-ZEM-CP3-5	Base Plate	6
			Support Beam	3
		<u>COLUMNS</u> CK-001-016-014	Top Column Adapter	6
			Lower Horizontal Beam	3
		<u>BEAMS</u> GT-001-016-014	Diagonal Brace	6
			Low Beam & Diagonal Brace Adapter	6
		Base 'Plate' CK-GT-001-016-805	HDG Bolt M10*35	168
			HDG Bolt M16*180	158
		GT-001-016-805	HDG Nut M10	168
			HDG Nut M16	156
		Column/Beam Adapters	HDG Washer M10	168
			HDG Washer M16	156
		Beam CK-GT-001-016-014	HDG Spring Washer M10	336
			HDG Spring Washer M16	312
		Column CK-001-016-014		
2		M Rail CK-ZEM-010-5760	M Water-proof Rail	26
			Self Tapping Screw	104
3		Water Channel CK-009-1062	Water Channel	36
4		Water Proof Strip CK-IP-160-1133	Water Proof Rubber	
5		Purlin 'C' Channel CK-PL-C140-001-016-6000	C-Channel 220 1/2"	6
			C-Channel 215 1/16"	6
			C-Channel 120 9/16"	6
6		L Angle Support	224 3/8"	4

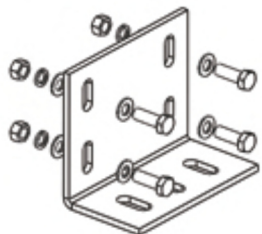
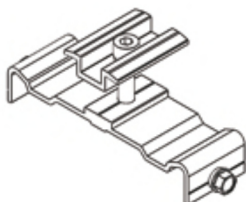
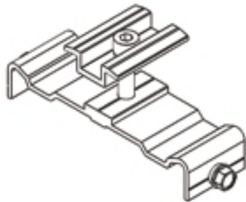
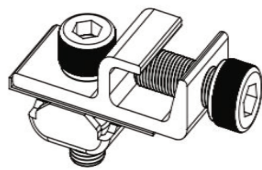
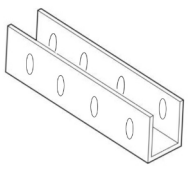
CAT	Picture	Description Part	Details	QTY
7		<p>C RAIL Purlin Fix Kit CK-PL-GT001-016-14</p>	Purlin Fixed Kit	18
			HDG Bolt M10*35	72
			HDG Bolt M16*140	36
			HDG Nut M10	72
			HDG Nut M16	36
			HDG Washer M10	144
			HDG Washer M16	72
			HDG Spring Washer M10	72
			HDG Spring Washer M16	36
8		<p>Mid Clamp CK-782-4-60-Q</p> <p>BRACKET # #CK-A845-801</p>	35mm Mid Clamp	88
			845 Share Plate	88
			M Grounding Plate	88
			Self Tapping Screw	352
			SS304 Bolt M8*45	88
			SS304 Spring Washer M8	88
9		<p>End Clamp CK-737-3-60-Q</p> <p>BRACKET # #CK-1845-801</p>	35mm End Clamp	16
			845 Share Plate	16
			M Grounding Plate	16
			Self Tapping Screw	24
			SS304 Bolt M8*45	12
			SS304 Spring Washer M8	12
10		<p>Grounding Lug CK-GTC-R2</p>	Grounding lug - weeb lug 8.0	6
			SS304 outer hex bolt 1/4" *0.6"	6
			SS304 inner hex bolt M8*20	6
			SS304 inner hex bolt M8*20	6
11		C Splice Bar	C Splice Bar	12

INSTALLATION STEPS

1. Build Base

Solution A, Build base

- ✓ Mark footer location according to the diagram. Verify all angles are square (See Attached Planset).
- ✓ Dig footers and make base with anchor bolts according to site conditions and system specifications and based on your structural engineer instructions for foundations requirements.
- ✓ If the ground is unlevel, ensure that all footer placements are level and at the same height regardless of the terrain elevation. Never install the structure tilted, the columns must always be straight.
- ✓ The structure's foundations should be calculated taking into account site conditions, soil type, seismic conditions, maximum wind and snow loads for the site location and the product mechanical loading specifications. In some cases, a geotechnical study is required. Please consult with your local structural engineer.
- ✓ In areas subject to freezing, footer depths may have to increase to resist freeze heave. Always consult a structural engineer to confirm footer depth and dimension.

Solution B, Concrete anchors

- ✓ Concrete anchors can be utilized if approved by a structural engineer.

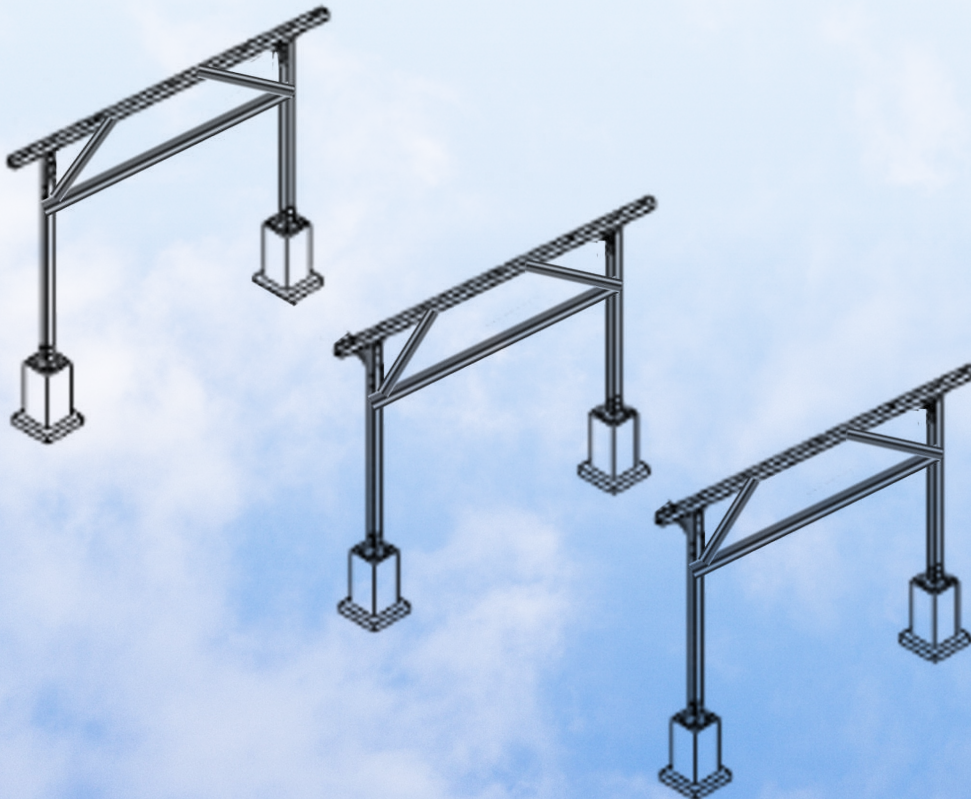

2. Install Base Plates

- ✓ Slide the column base plate over the concrete anchors and secure them. If you are using leveling nuts to level the column base plate. Correct any shifting if needed and repeat for the other three column base plates. Fill the gap between the base plate and the footing with Dry-pack non-shrink grout.
- ✓ Verify the distance between the front and rear column conform with the attached planset.

Products Name	Quantity
Base	6

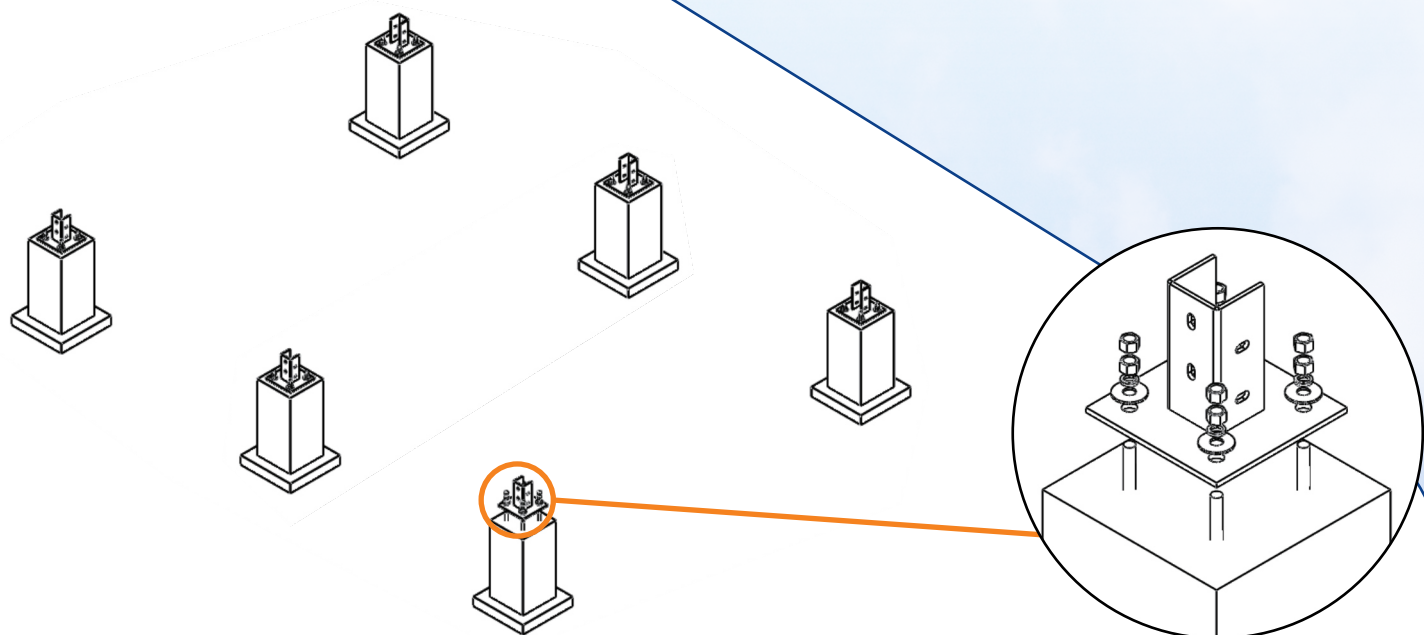

3. Fix Adapter

- ✓ A . Fix Low Beam/Diagonal Brace Adapter to Front & Rear Columns
- ✓ B1. Attach C-Rail Fix Kit to Support Beam
- ✓ B2. Attach Top Column Adapter to Support Beam

Front Column: 111"
 Rear Column: 126 7/16"
 Low Beam/Diagonal Brace Adapter: 16 1/2"
 Top Column Adapter: 10 3/16"
 Support Beams: 228 5/16"

Products Name	Quantity
Top Column Adapter	6
M16*140mm Bolt Kits (1 big flat washer + 1spring washer + 1 nut)	48
Low Beam/Diagonal Brace Adapter	6
C-Rail Fix Kit	18

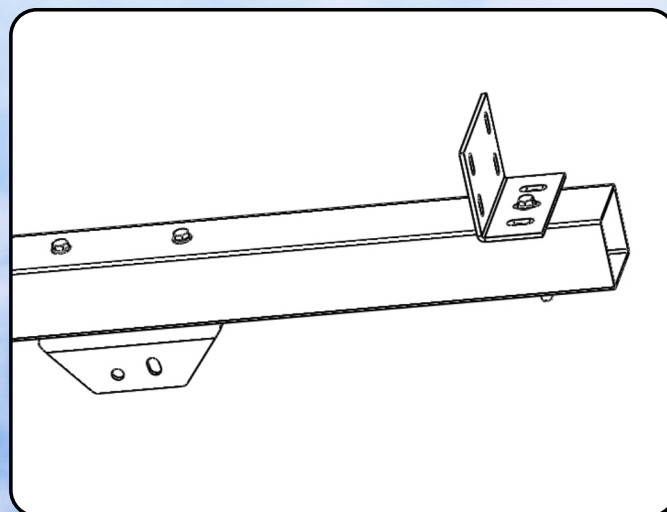
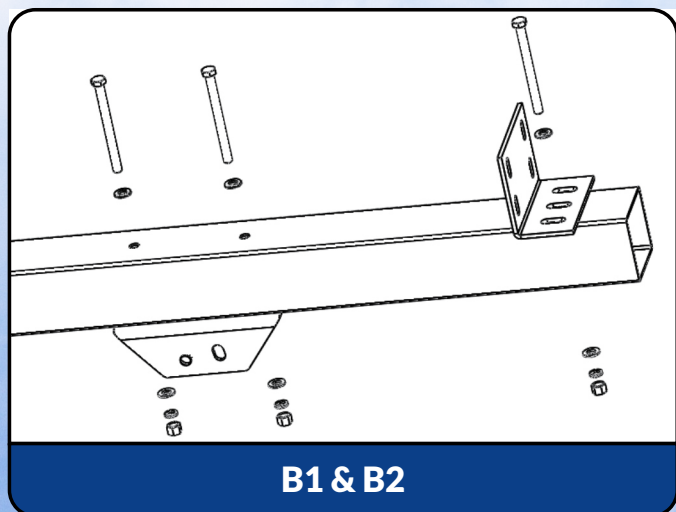
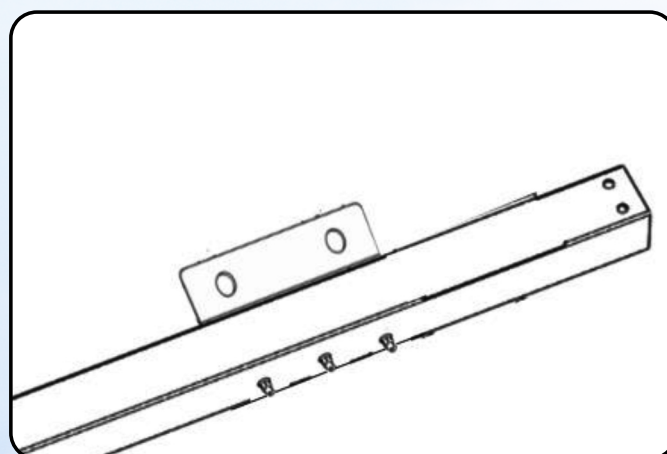
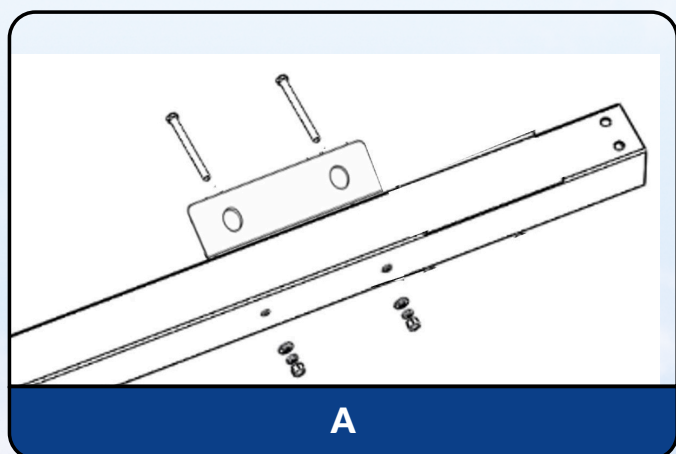

4. Connect Columns

✓ Attach Columns to base plate

Products Name	Quantity
Front Columns --- 111"	3
Rear Columns --- 126 ½"	3
M16 *180mm Bolt Kits (1 flat washer + 1 spring washer + 1 nut)	24

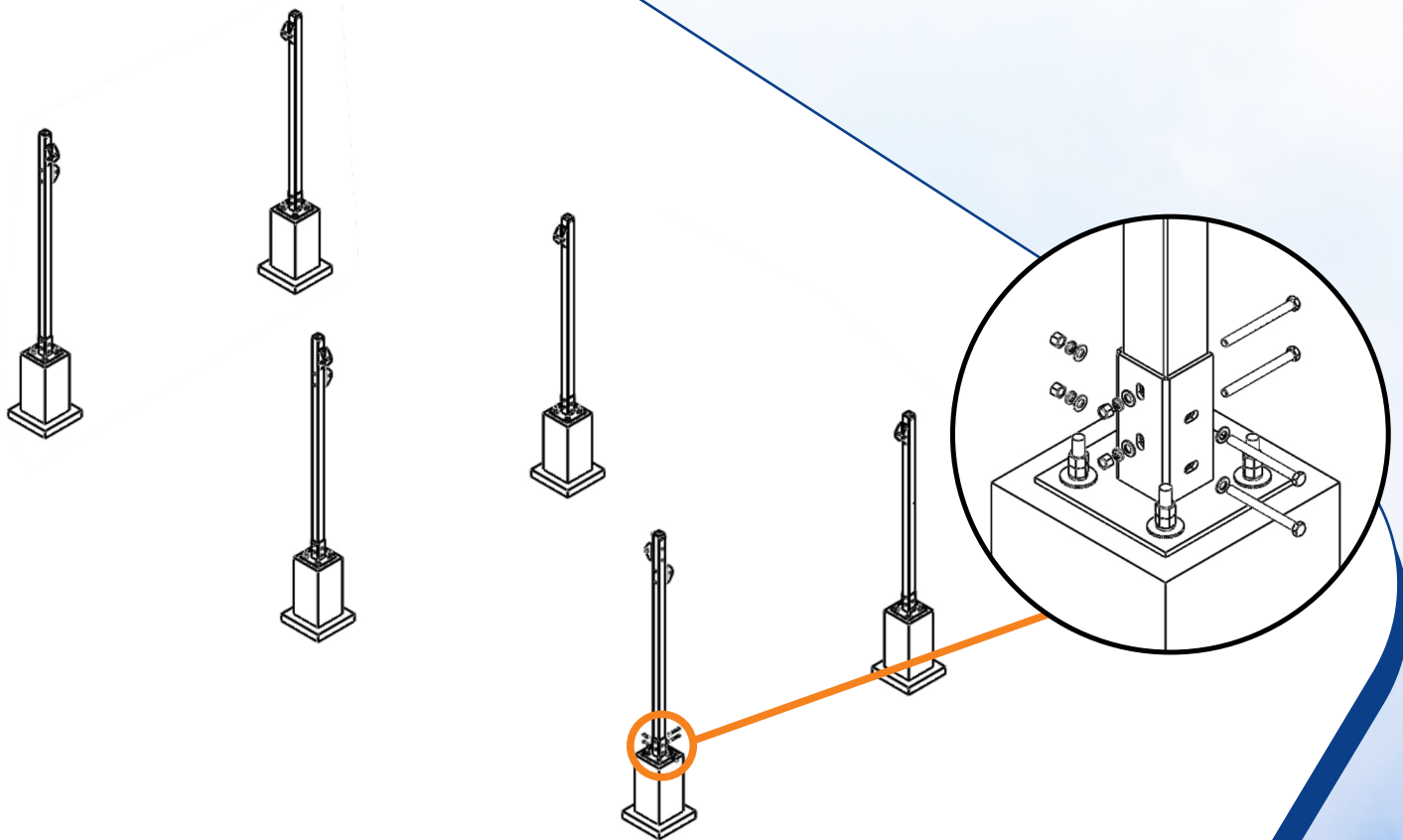

5. Connect Beams

- ✓ Connect Lower Horizontal Beam to front and rear Columns
- ✓ Connect Support Beam between front and rear columns on top
- ✓ Connect Diagonal Brace between Support Beam and Column

Products Name	Quantity
Lower Horizontal Beam 168 ¹ / ₁₆ "	3
Support Beam 228 ⁵ / ₁₆ "	3
Diagonal Brace 47 ³ / ₁₆ "	6

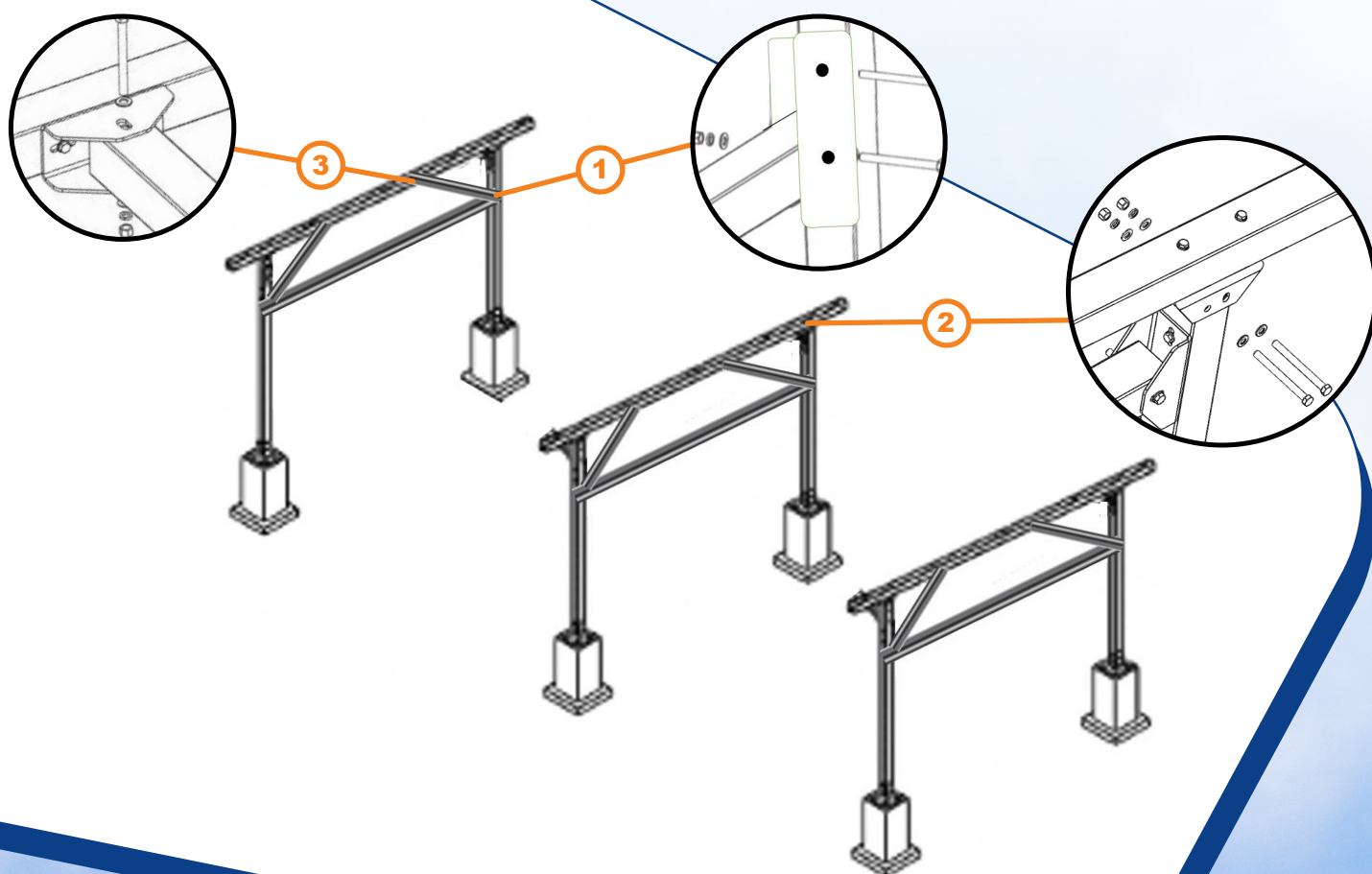

6. Fix C Rail

- ✓ Combine C-Rails with C-Rail Splice Kit
- ✓ Use C-Rail Fix Kit to connect C-rails to Support Beam
- ✓ Use M10*16mm Bolt Kits (1 flat washer + 1 Spring Washer + 1 Nut)
- ✓ Use M10*25mm Bolt Kits (1 flat washer + 1 Spring Washer + 1 Nut)

Products Name	Quantity
C Rail --- 220 1/2"	6
C Rail --- 215 1/16"	6
C Rail --- 120 9/16"	6
C-Rail Fix Kit	18
C-Rail Splice Kit	12
M10*40mm Bolt Kits (1 flat washer + 1 spring washer + 1 nut)	48
M16*140mm Bolt Kits (1 flat washer + 1 spring washer + 1 nut)	24

*When spliced, total length of C-Rail is 556 1/8"

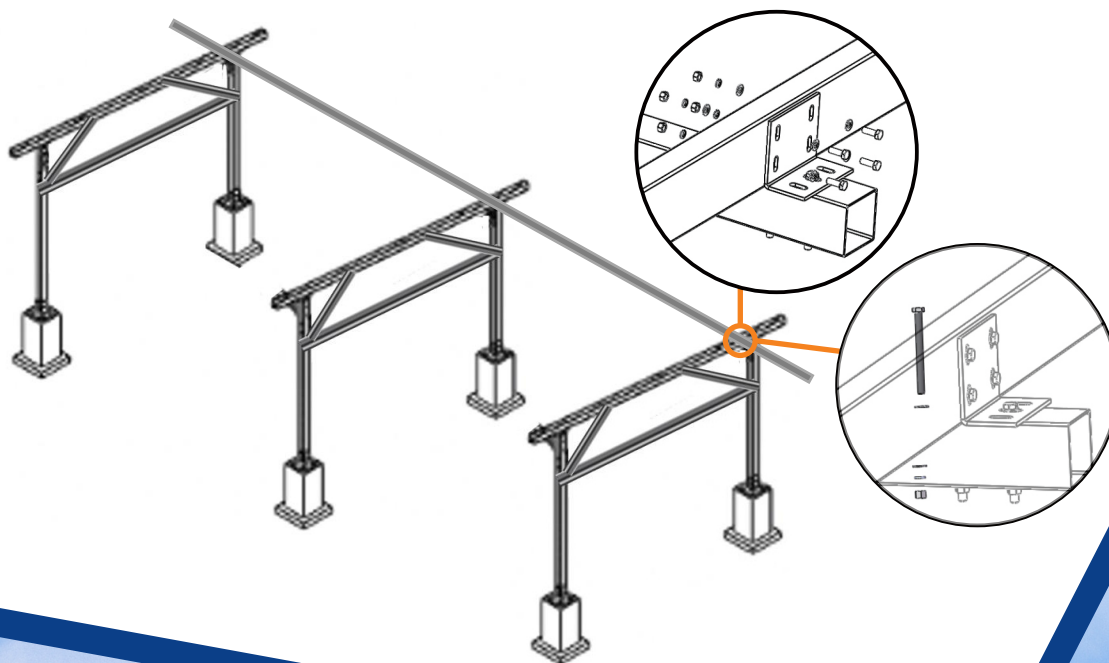

7. Pre-assemble clamps on M Rail

Overlap 2qty M-Rails, attach the 2 M-Rails together with 2 M6*16, ensure overlap is facing toward low slope side of installation, ensuring water flow over top of M-rails connection point. Apply waterproof adhesive at seam where 2qty M-rails overlap after they have been mechanically attached.

- ✓ Pre-fix share plate to M rail
- ✓ Connect mid clamps to share plate
- ✓ Please check L1/L2/L3/L4 before fixing

TIP: Place 2 M-Rails in parallel on a flat level surface, then lay 3 or 4 panels in portrait on top of The M-Rails, ensuring proper spacing, then mark your share plate locations. Use these Measurements to install the remaining share plates on the remaining M-Rails.

Products Name	Quantity
M Rails – 142 1/8”	26
Share Plates	88
Mid Clamps	88
End Clamps	16
M6.3*16	416

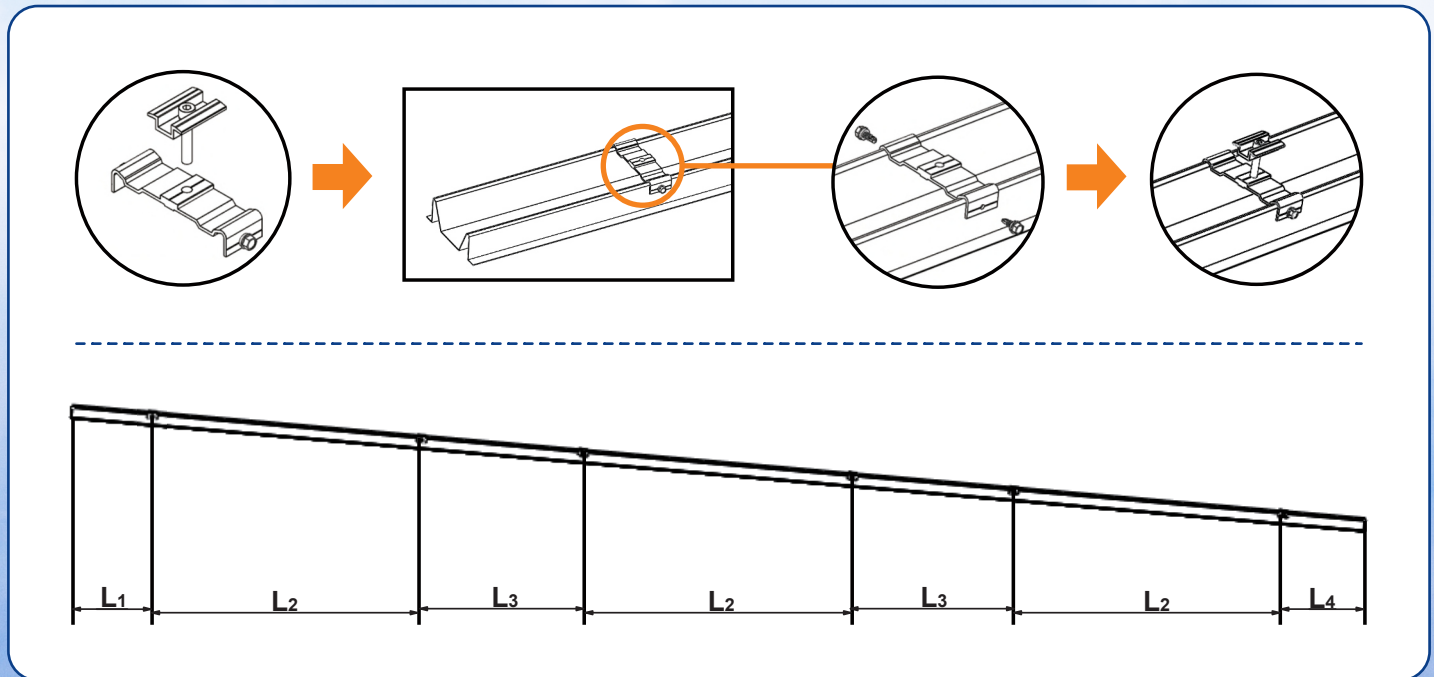

8. Fix M Rail

- ✓ Use M6.3 self tapping screw to fix M rail to C Rail
- ✓ With end clamps on the side M Rails
- ✓ With mid clamps on the inner M Rails
- ✓ Please check the L measurement before attaching

TIP: If possible lay M-Rails on flat level surface, place panels across M-Rails in portrait configuration, ensure rails and panels are square; take measurement to confirm starting M-Rail location.

Please Review Math Calculation in Appendix

Products Name	Quantity
M Rails 142 1/8"	26
M6.3	260

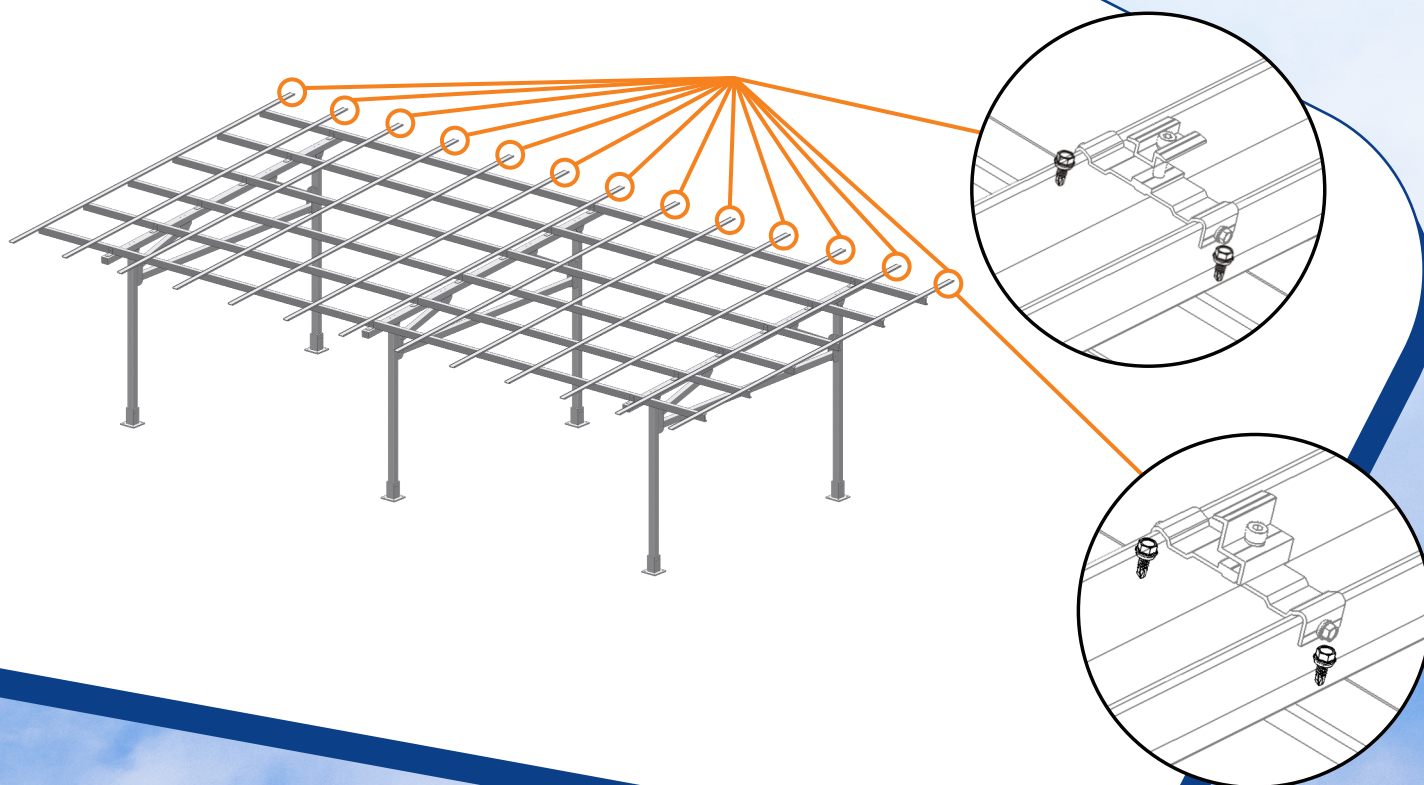

9. Install Solar Panels

- ✓ For waterproofing stick rubber molding to exterior of module frame but only where the frames are adjacent to other module frames or on all interior seams
- ✓ Install water channel where 2 panels meet under the module frame

Products Name	Quantity
Modules	36 or 48
Rubber	1 Roll
Water channel	24 or 36

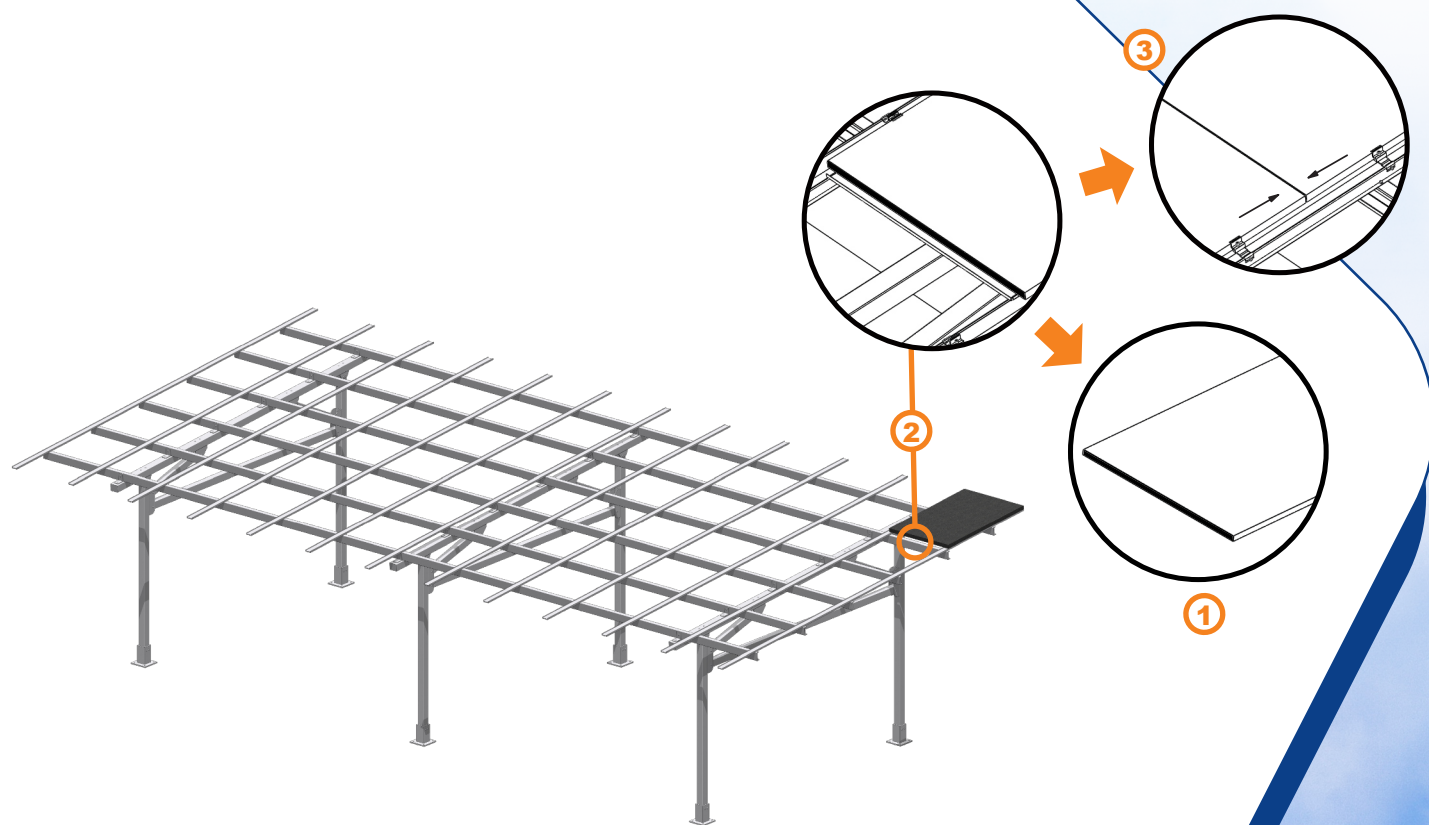

10. Grounding- Lug and Wiring

Install grounding lug at end of C-Rail on side of array that is most optimal for wire management. Ensure that all paint and any debris is removed from bonding site to achieve proper bonding connection. Attach each ground lug with a stainless steel nut then cross 8.4mm² or greater than or equal to 8AWG copper wire through all 6 grounding lugs (fixed by M8*20 inner hex bolt), finally connect copper wire to the ground. The grounding lug completes a grounding function when fastened tight to connect all 6 C Rails and copper wire.

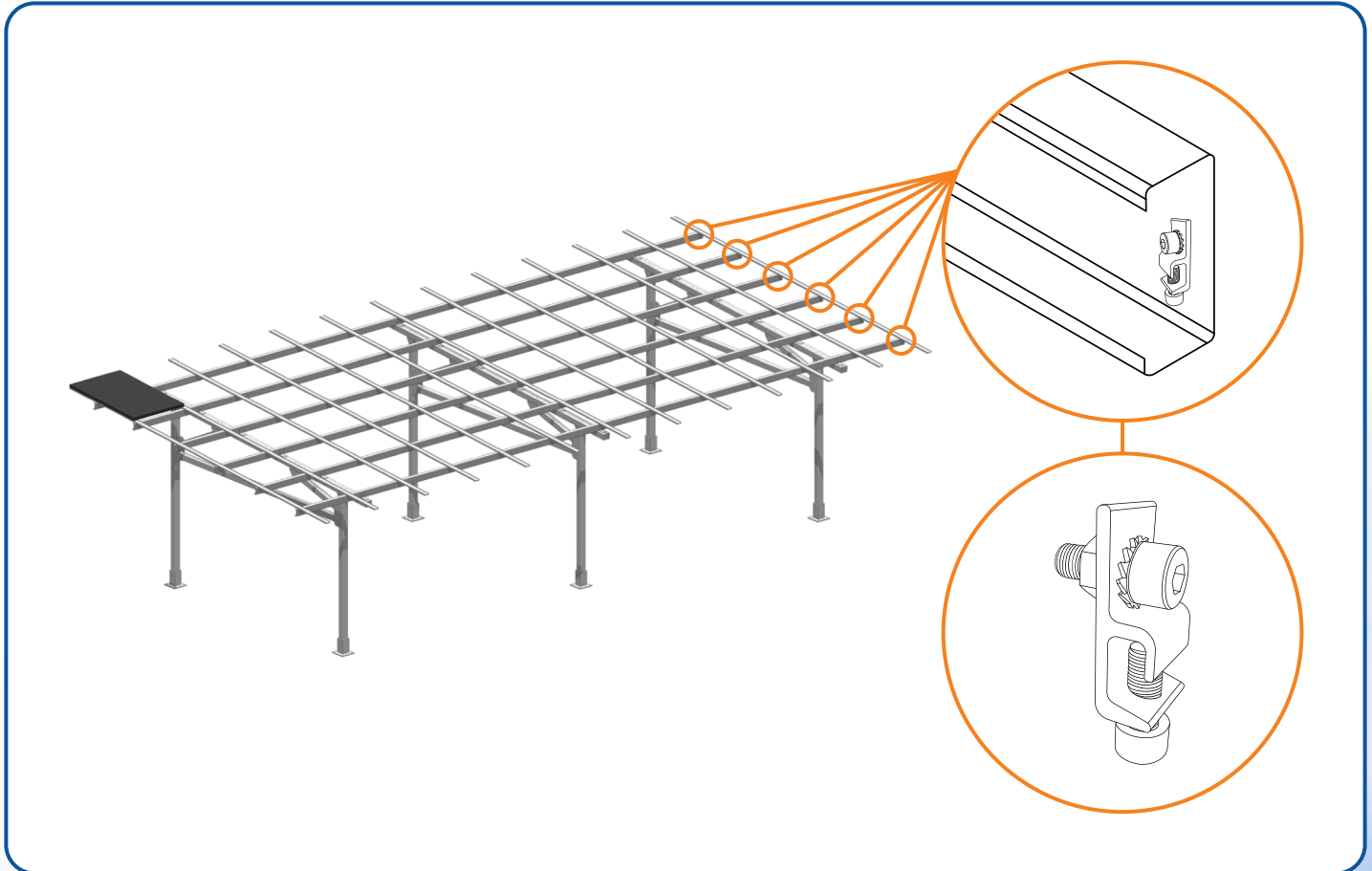

Electrical Characteristics of AWG Copper Wire

AWG	Diameter [inches]	Diameter [mm]	Resistance [Ohm / 1000ft.]	Resistance [Ohm / km]	Max Current [Amperes]	Max Frequency for 100% skin depth
6	0.162	4.1148	0.3951	1.295928	37	1100 Hz
7	0.1443	3.66522	0.4982	1.634096	30	1300 Hz
8	0.1285	3.2639	0.6282	2.060496	24	1650 Hz
9	0.1144	2.90576	0.7921	2.598088	19	2050 Hz
10	0.1019	2.58826	0.9989	3.276392	15	2600 Hz

Grounding - Lug and Wiring Diagram

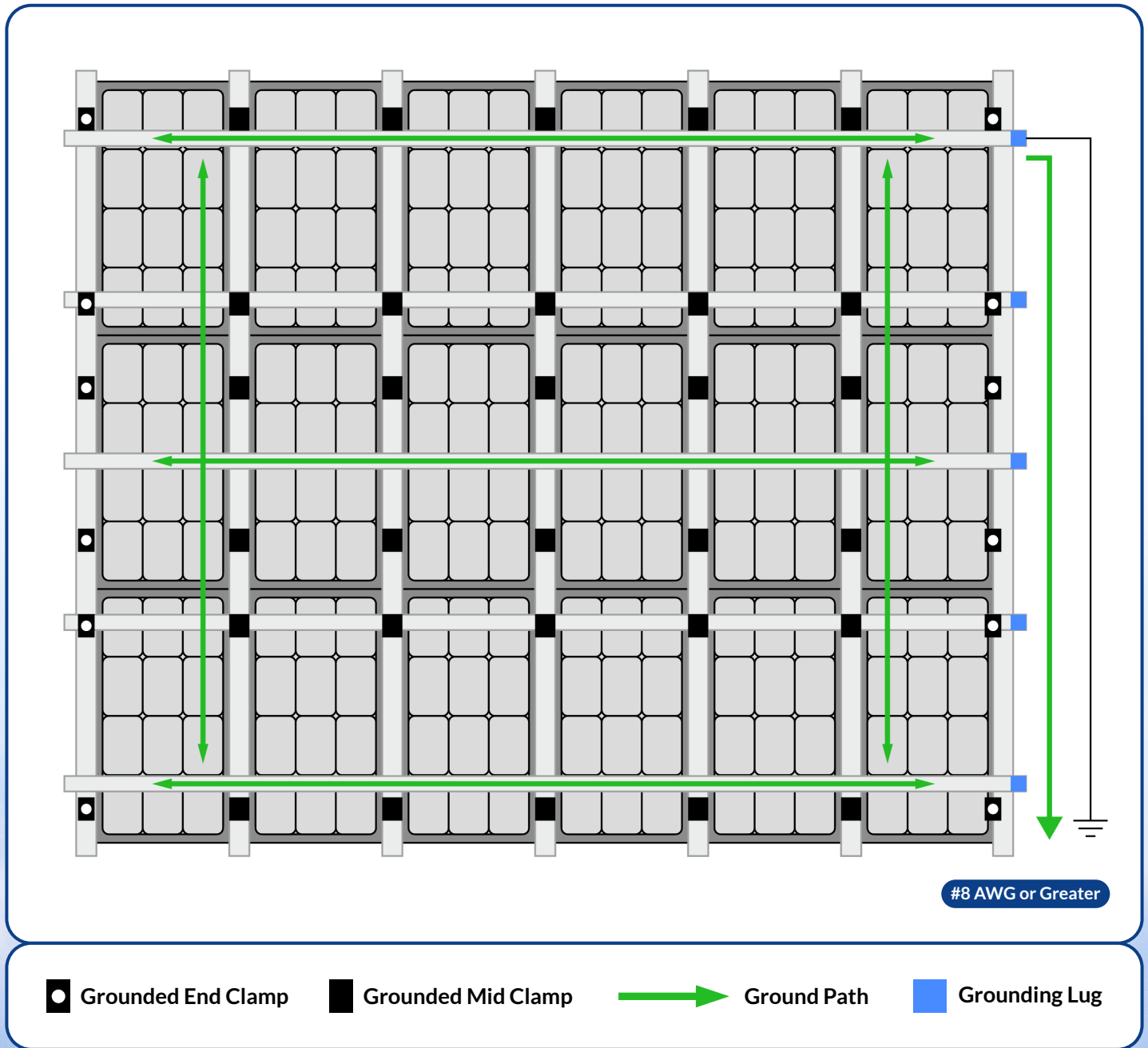

11. Final Check

- ✓ Check and verify that all components are properly fastened and installed properly in their correct positions and locations.
- ✓ Verify and re-adjust all components as needed within the structure.

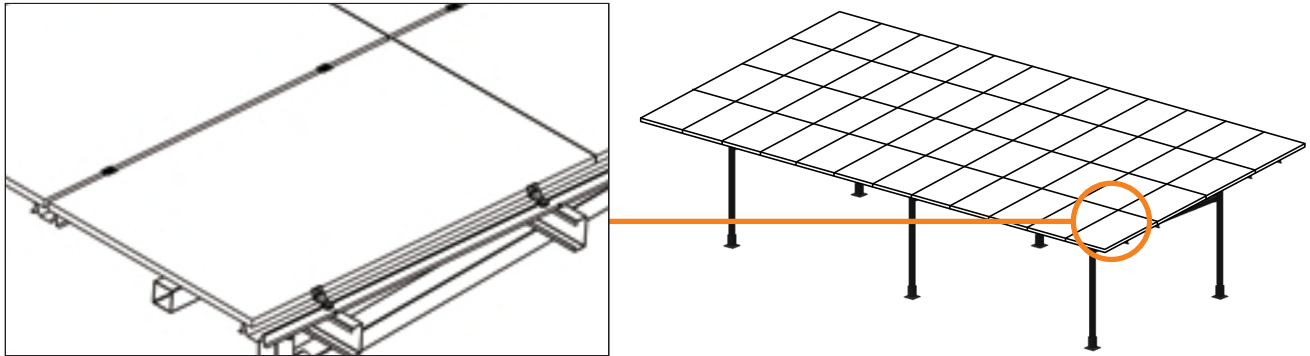

12. Hide Footing (Optional)

- ✓ Cladding of 4 bases is an option with engineer approval.

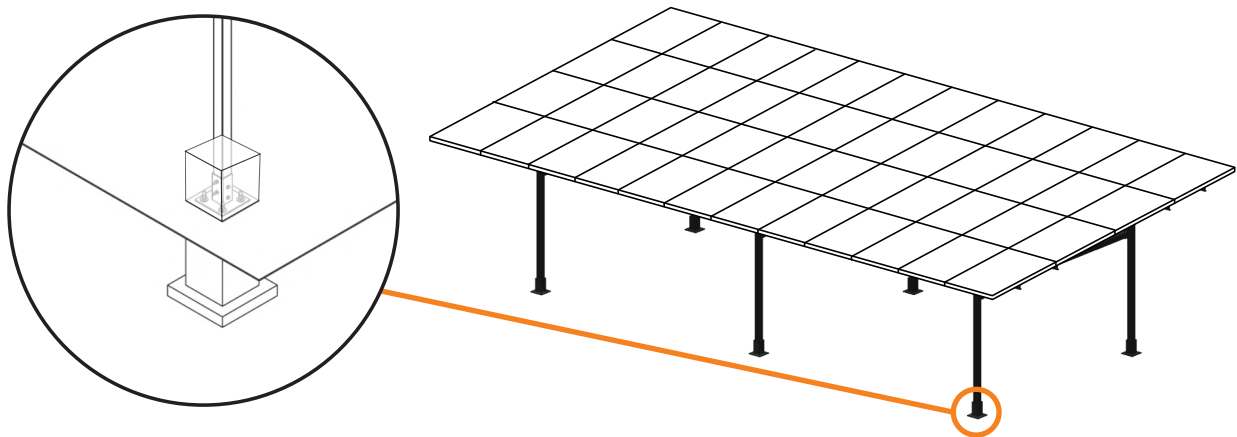

WORLDLEADING

M A N U F A C T U R E

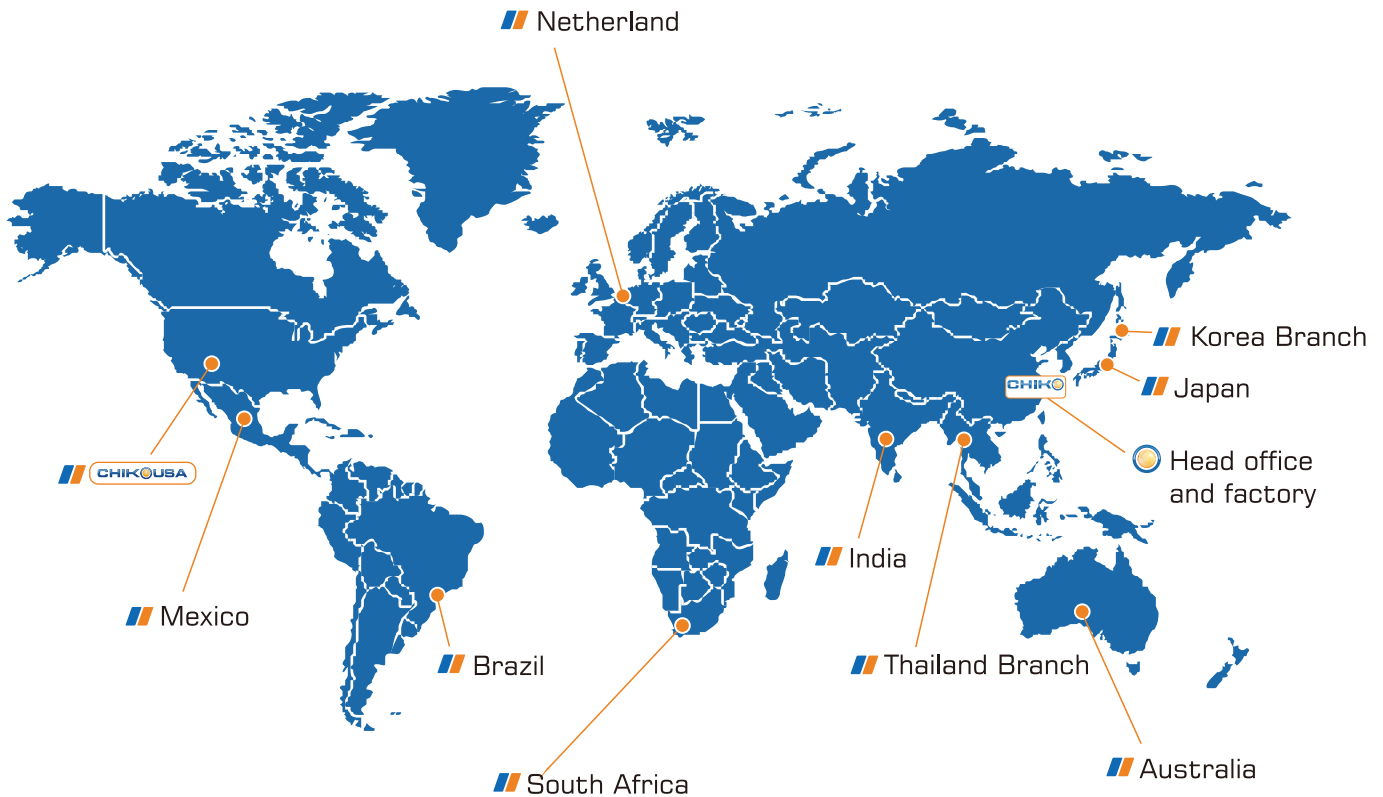

CHIKOUSA
RACKING MADE SIMPLE

Tel : 1-800-948-5390

Email : info@chikousa.com

www.chikousa.com



101 East Baseline Road
Buckeye, AZ 85326

FOUR CAR CARPORT

Panel Layout : 4x12

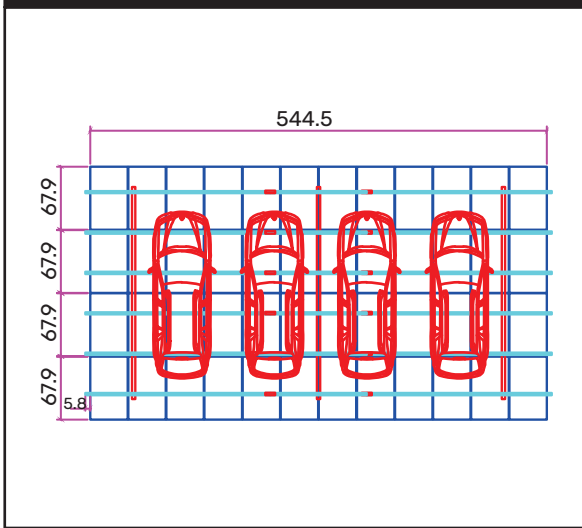

C Rail Layout

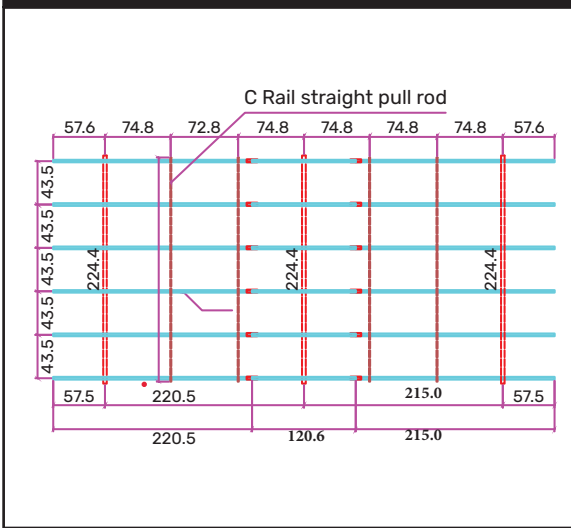

C Rail & M Rail Layout

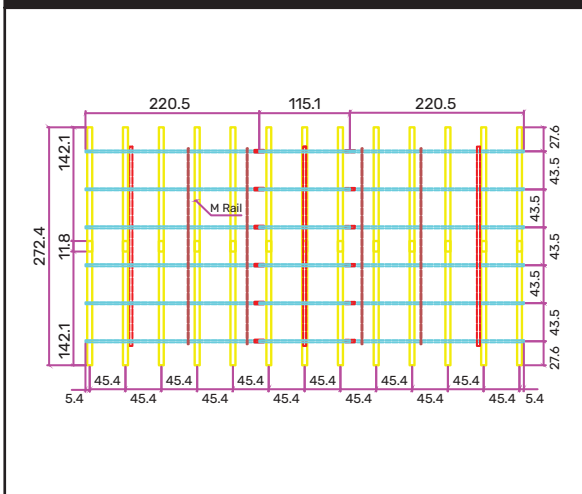

Foundation Layout

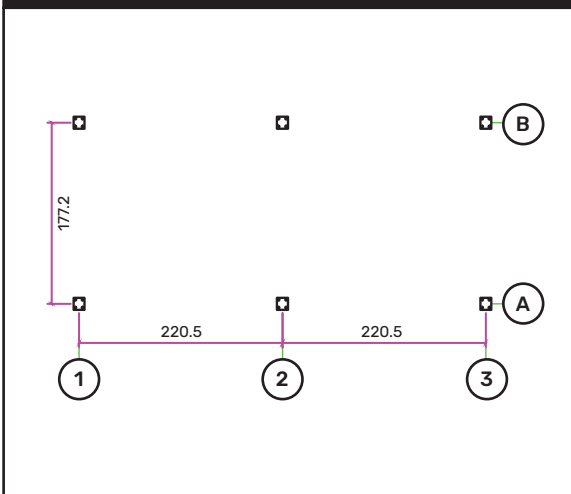

Layout : 4x12

BOM

NO	DESCRIPTION	QTY
1	Beam & Column Set	3
2	End Clamp	16
3	End Clamp bracket	16
4	Mid Clamp	88
5	Mid Clamp bracket	88
6	C Rail fix kit	18
7	C Rail 220.5	6
8	C Rail 120.6	6
9	C Rail 215.0	6
10	C Rail Splice Kit	12
11	M Rail - 142.1	26
12	C Rail straight pull rod - 224.4	4
13	Waterproof channel- 41.8	36
14	Waterproof pad - 44.6	36
15	M6. 3*16 (M Rail)	104
16	M6. 3*16 (End & Mid Clamp bracket)	160
17	M6. 3*25 (M Rail & C Rail)	208

Design Factors :
 Module Dimensions : 6 . .6
 Tilt Angle : 5°
 Front Clearance : 111
 Wind Speed :
 Snow Load : --

Modify by	Doc No.	Data	Des	J. Burton	231130
			Drw		
			Check		
			Craft		
			App		

CHIKOUSA

Beam & Column Set

4x12-5°

View :

Rate

Page /

CHIKO CARPORT- - BASE PLATE DRAWING - IN INCHES

BASEPLATE BOTTOM DIMENSION SQUARE: 11 13/16" X 11 13/16"

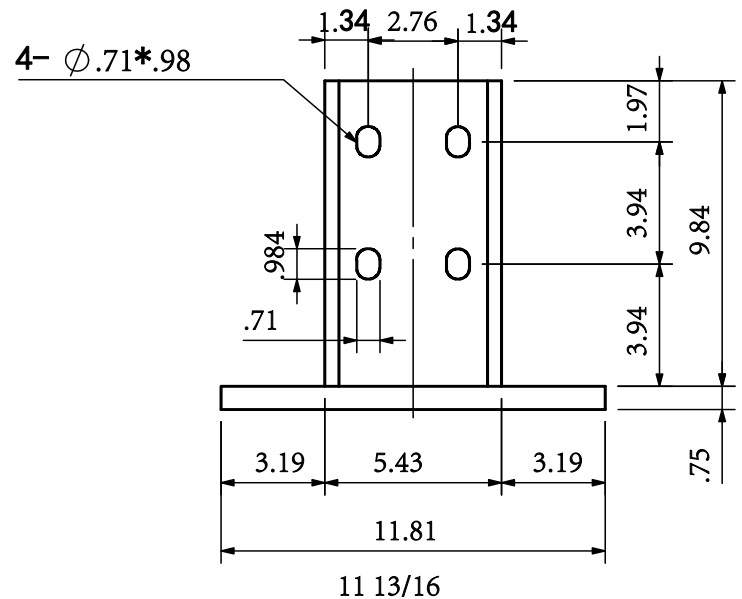
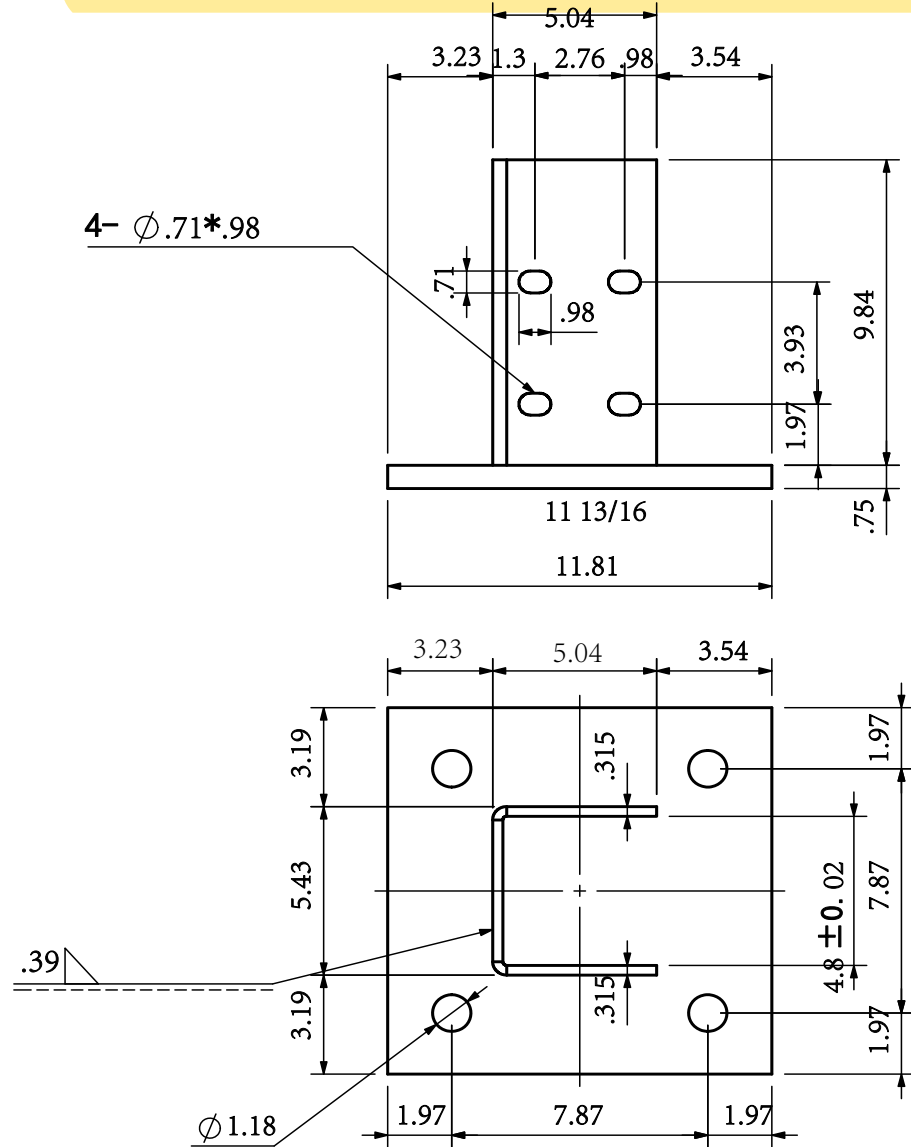

Des.		CHIKOUSA	
Drw.	Bowen231124	Material Steel	Name.名称: Base Plate
Check.			Part # CK-GT-001-019-807
Crsft.		View.:	Scale.
App.			Page.

CHIKO CARPORT- - BASE PLATE DRAWING - IN MM

BASEPLATE BOTTOM DIMENSION SQUARE: 300MM X 300MM

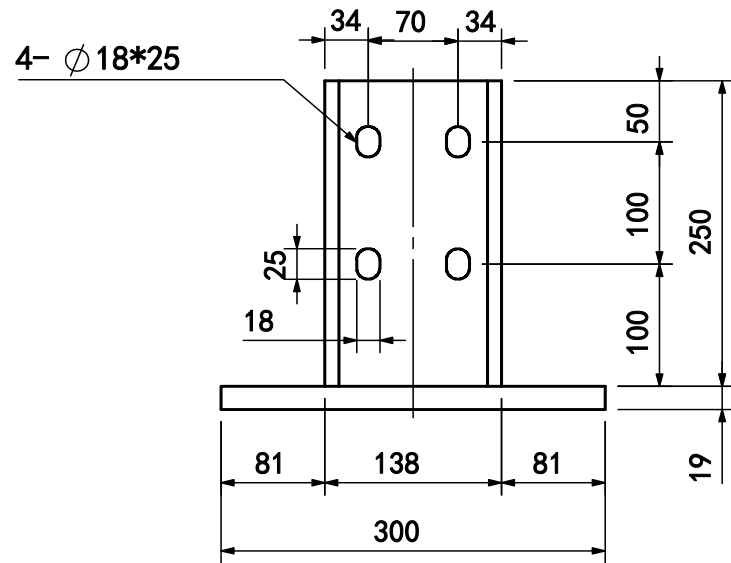
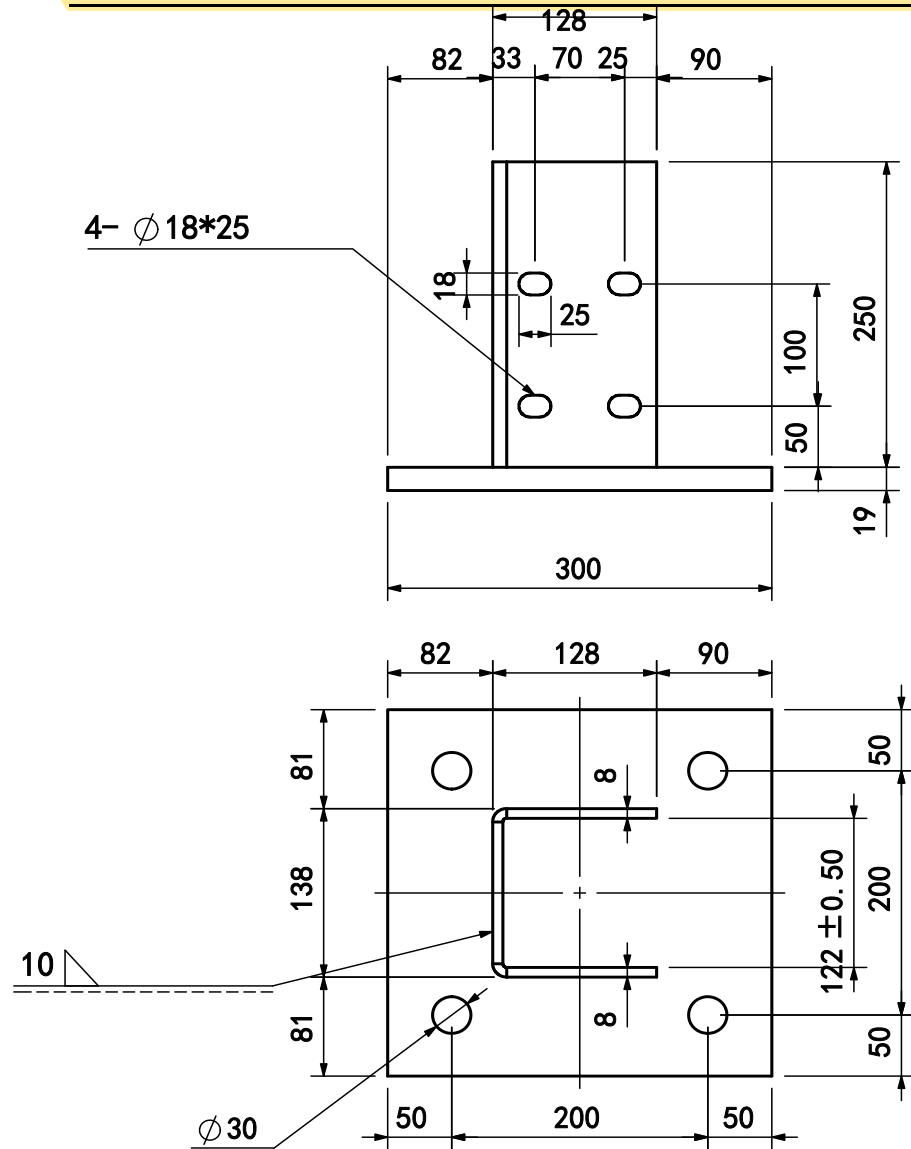

Des.		CHIKOUSA	
Drw.	Bowen231124	Material	Q235B
Check.		Steel	Name.名称: Base Plate
Crsft.I.		View	Part # CK-GT-001-019-807
App.		Scale.	Page.

CHIKO USA PREMIER CARPORT-SIDE VIEW

INCHES

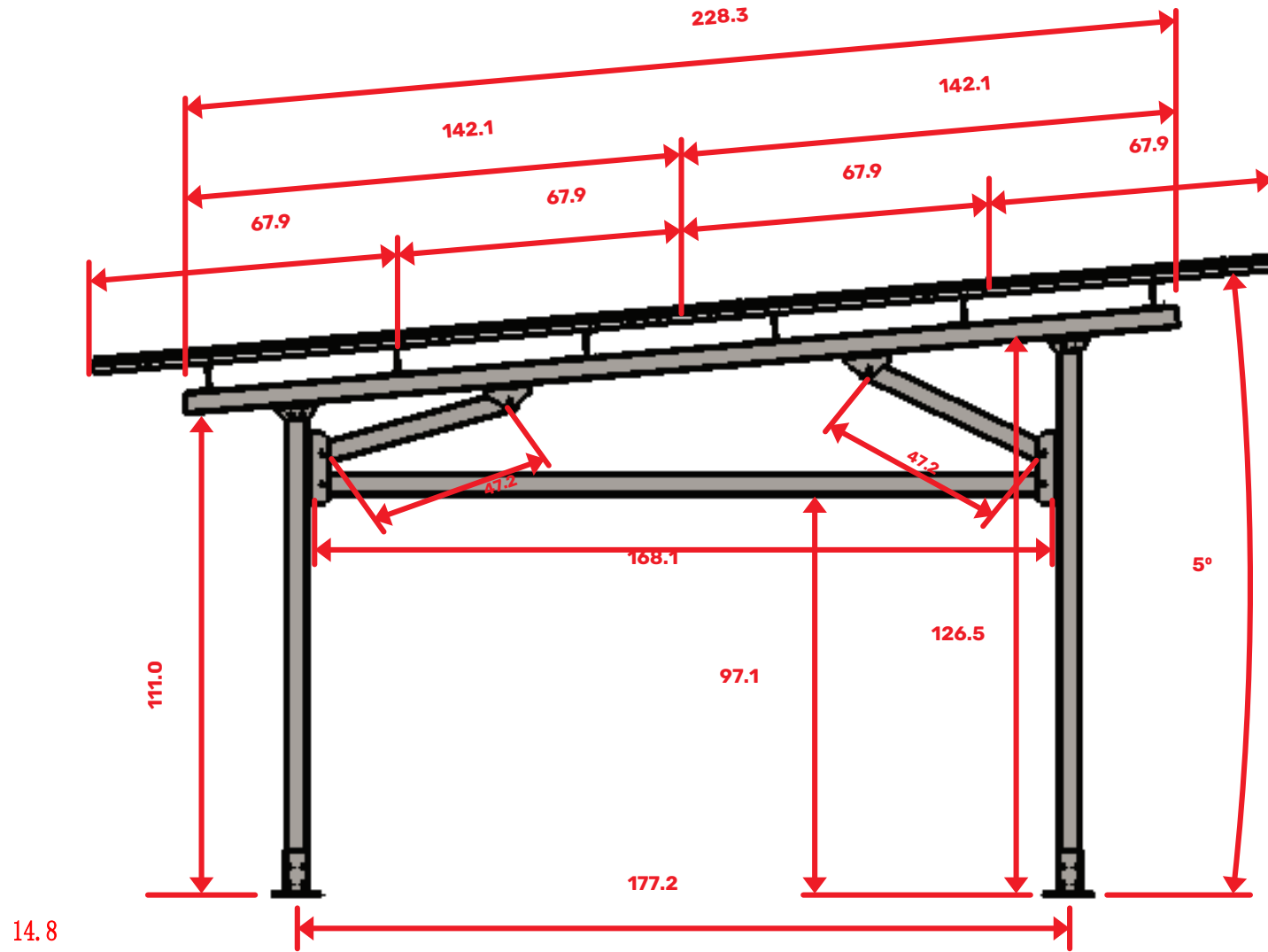

1	Mark	Modifivation	Modify by	Doc No.	Data	Des	J. Burton	231130	CHIKOUSA		
						Drw					
						Check			4x6-5°		
						Craft					
						App			View :	Rate	Page /

A

B

C

D

SIDE PROFILE AND PARTS DIAGRAMS

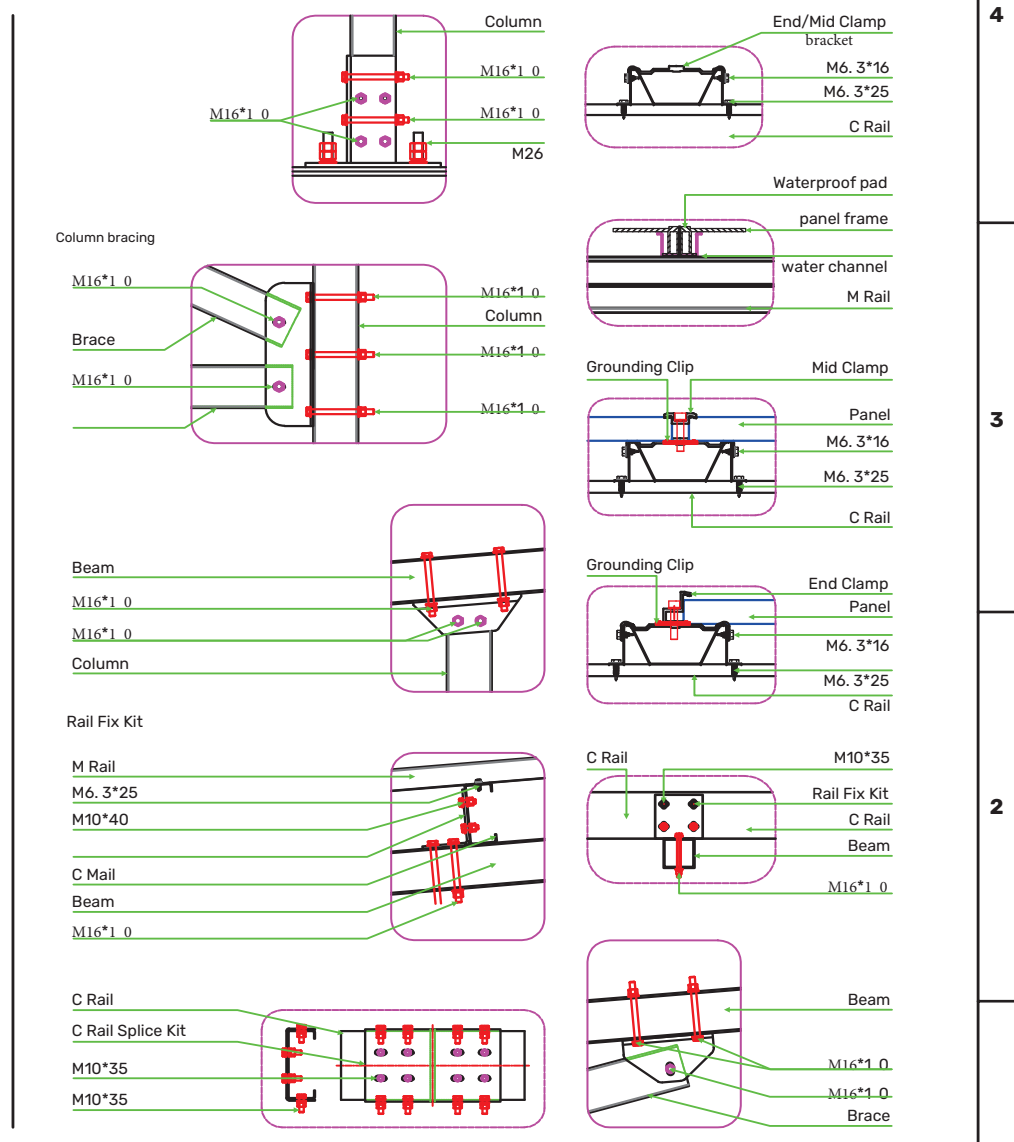
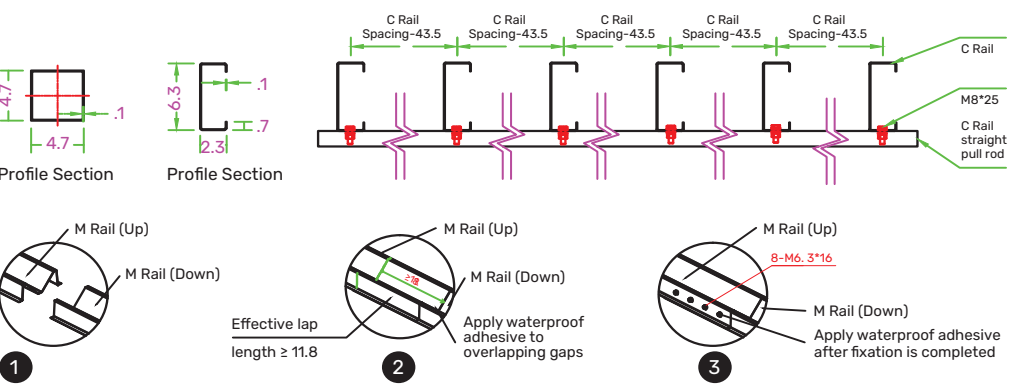
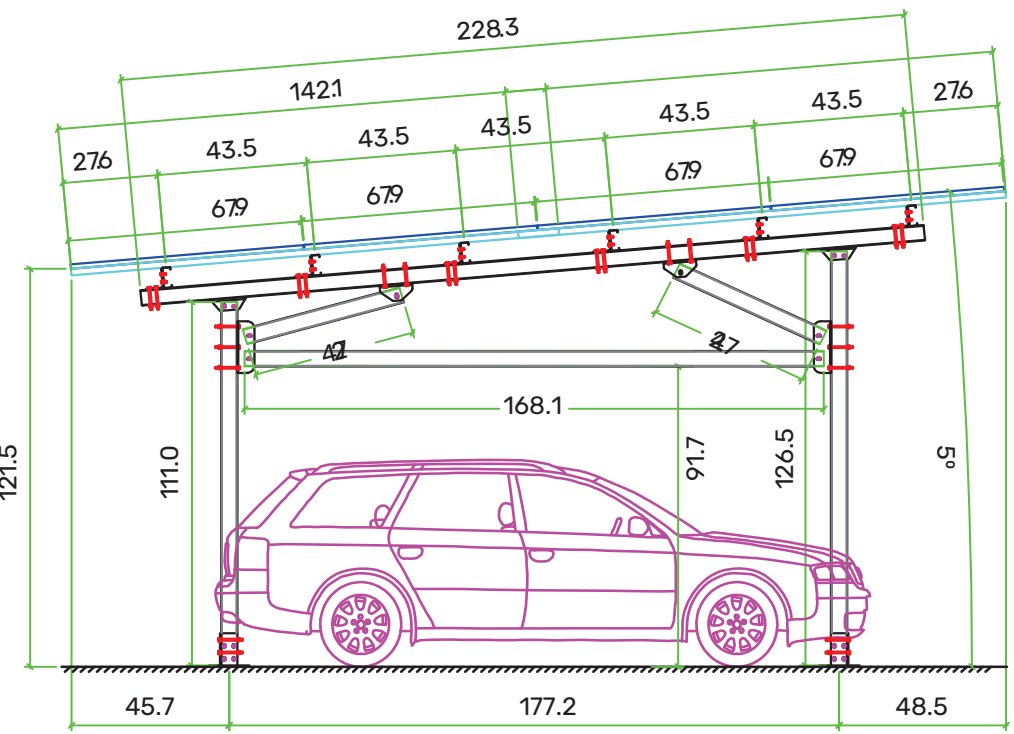

Design Factors	:	
Module Dimensions	:	67.9 x 44.6
Tilt Angle	:	5°
Front Clearance	:	111
Wind Speed	:	--
Snow Load	:	--

Modify by	Doc No.	Data	Des	J. Burton	231130
			Drw		
			Check		
			Craft		
			App		

CHIKOUSA

Beam & Column Set
4xa-5°

View:

Rate	Page /
------	--------

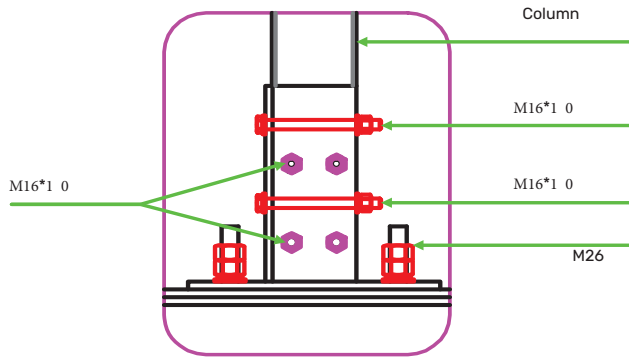

Column bracing

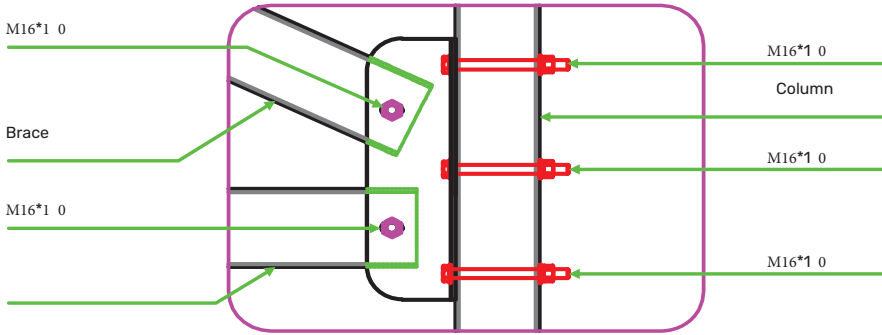

Beam



Rail Fix Kit

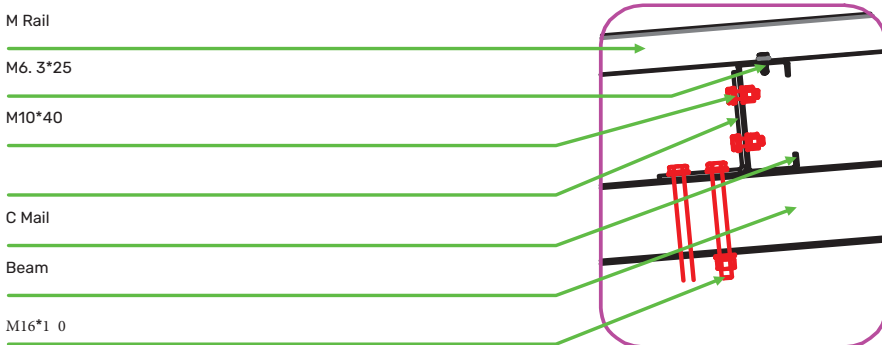

C Rail

